

The SHAKEN Governance Model: Setting Robocall Mitigation Protocols into Action in the Network

Moderator:
Brent Struthers
STI-GA Director
ATIS

May 14, 2019



Advancing ICT Industry Transformation



Brent Struthers
STI-GA Director
ATIS



Jim McEachern
Principal Technologist
ATIS

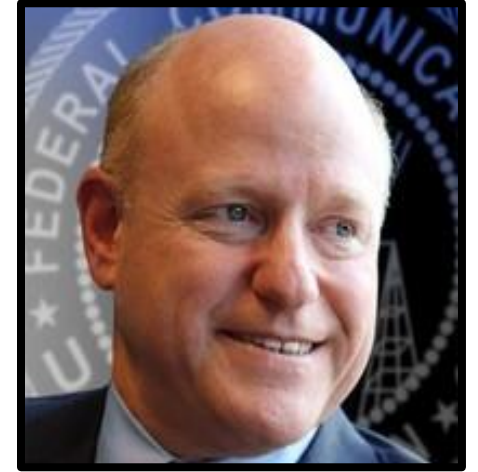

Eric Burger
Chief Technology Officer
FCC



Linda Vandeloop
AT&T
STI-GA Board Chair



Marian Hearn
Executive Director
CSTGA



Outline

- SHAKEN Governance Model
- Call Authentication Trust Anchor Working Group
- Secure Telephone Identity- Governance Authority (STI-GA) Update
- Canadian Governance Authority

Phase 1: ATIS-100074 SHAKEN Specification

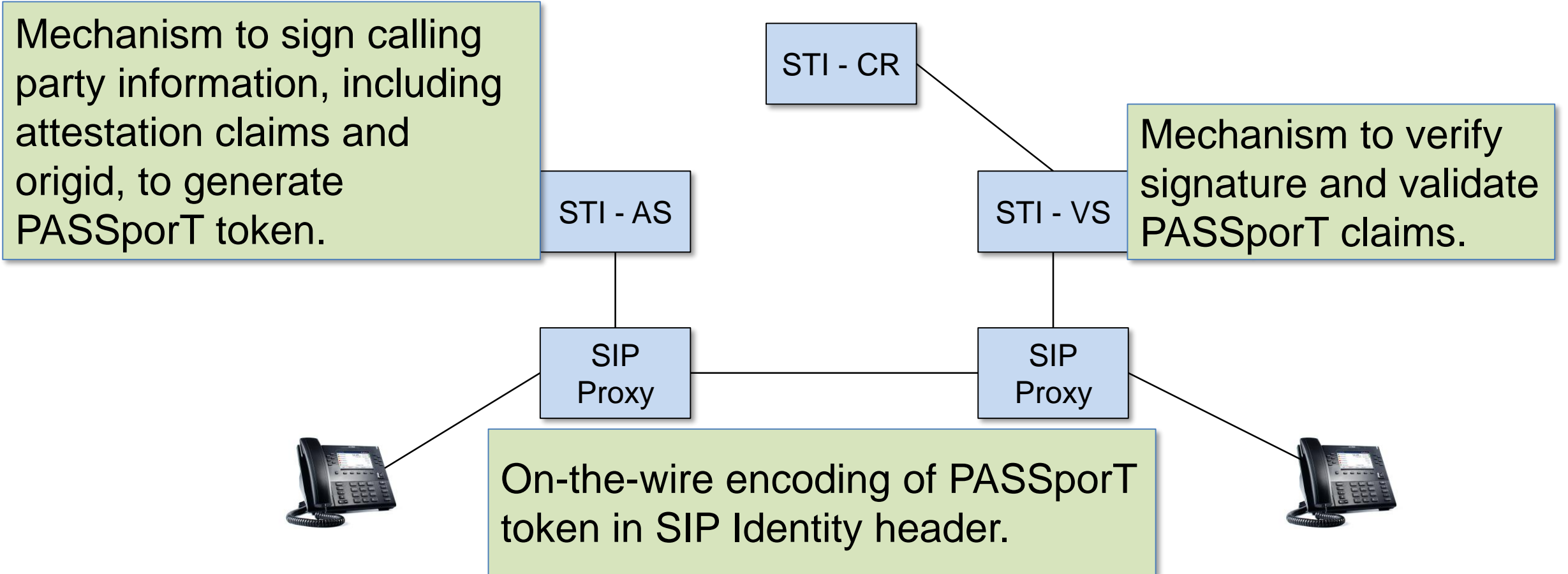

ATIS-1000074: Signature based Handling of Asserted information using ToKENs (i.e., SHAKEN)

Phase 2: ATIS-1000080 SHAKEN Governance Model

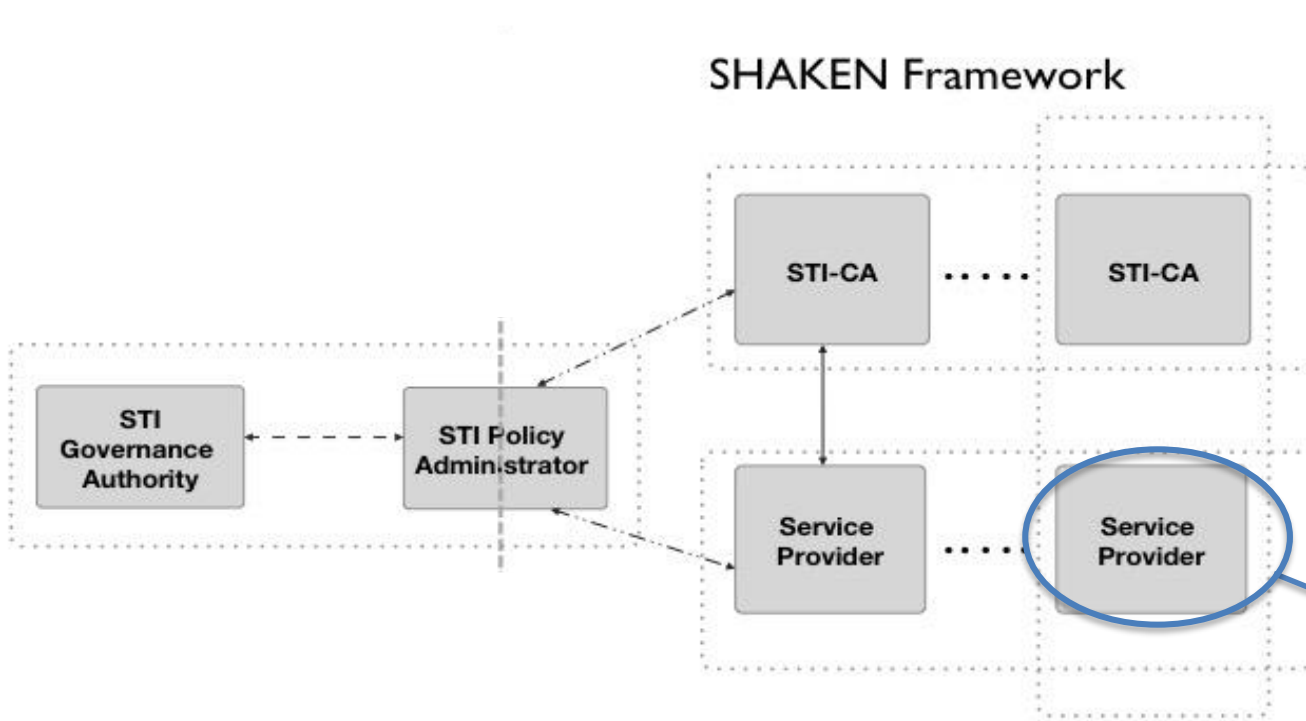

SHAKEN Governance Model and Certificate Management defines mechanism for service provider to obtain SHAKEN STI Certificates:

- Roles
- Protocols

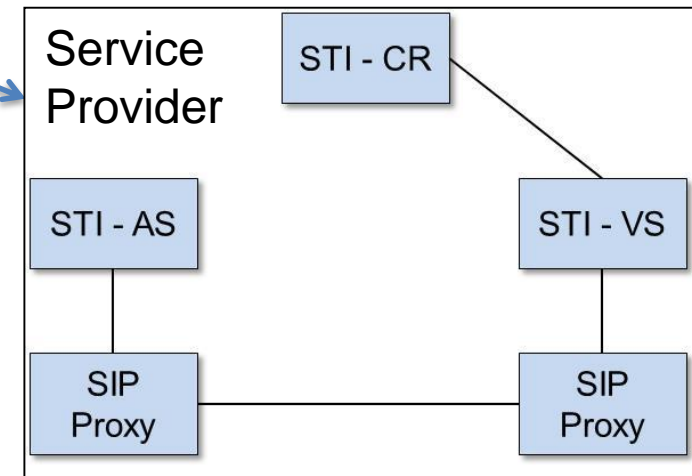

ATIS-1000080: SHAKEN: Governance Model and Certificate Management

Industry-Developed SHAKEN Governance Model

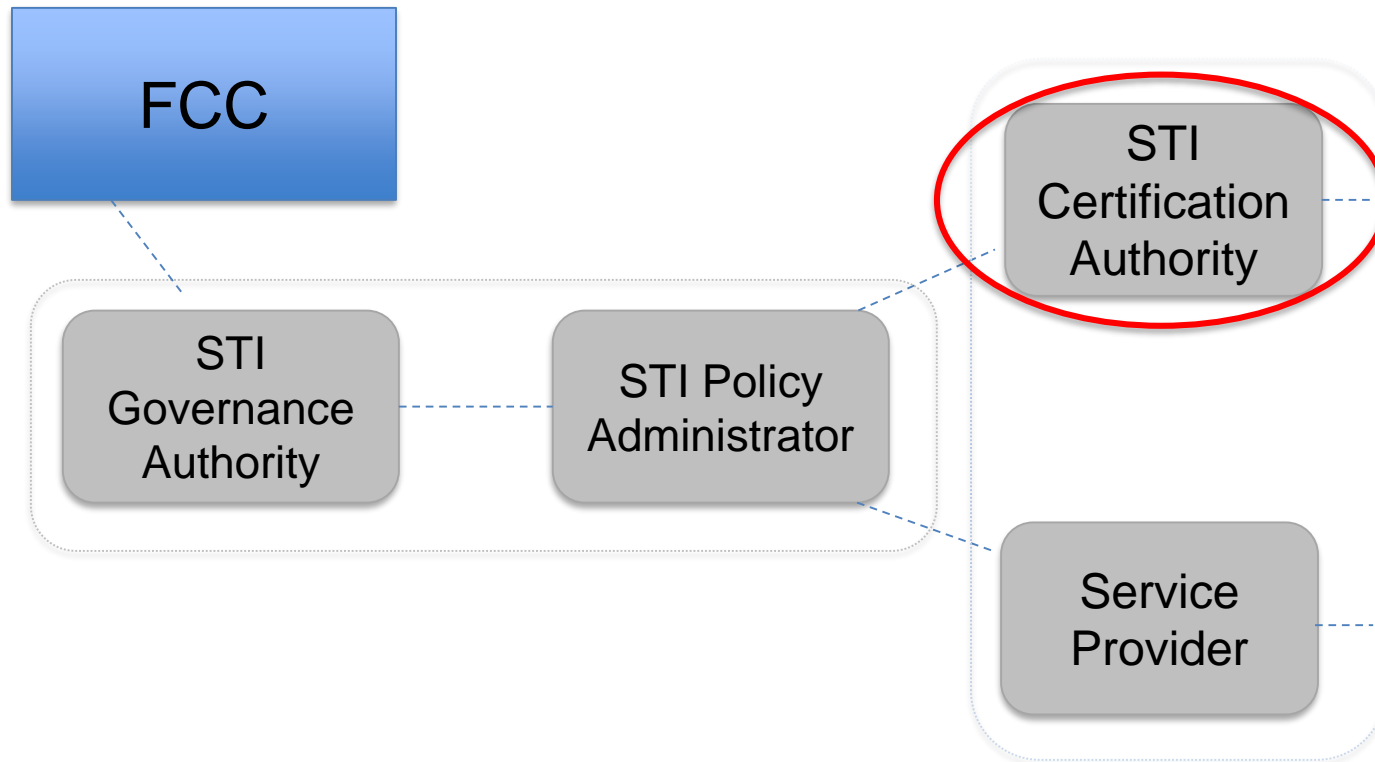

Key roles:

STI Certification Authorities (STI-CA)

- Issues STI Certificates to service providers

Industry-Developed SHAKEN Governance Model

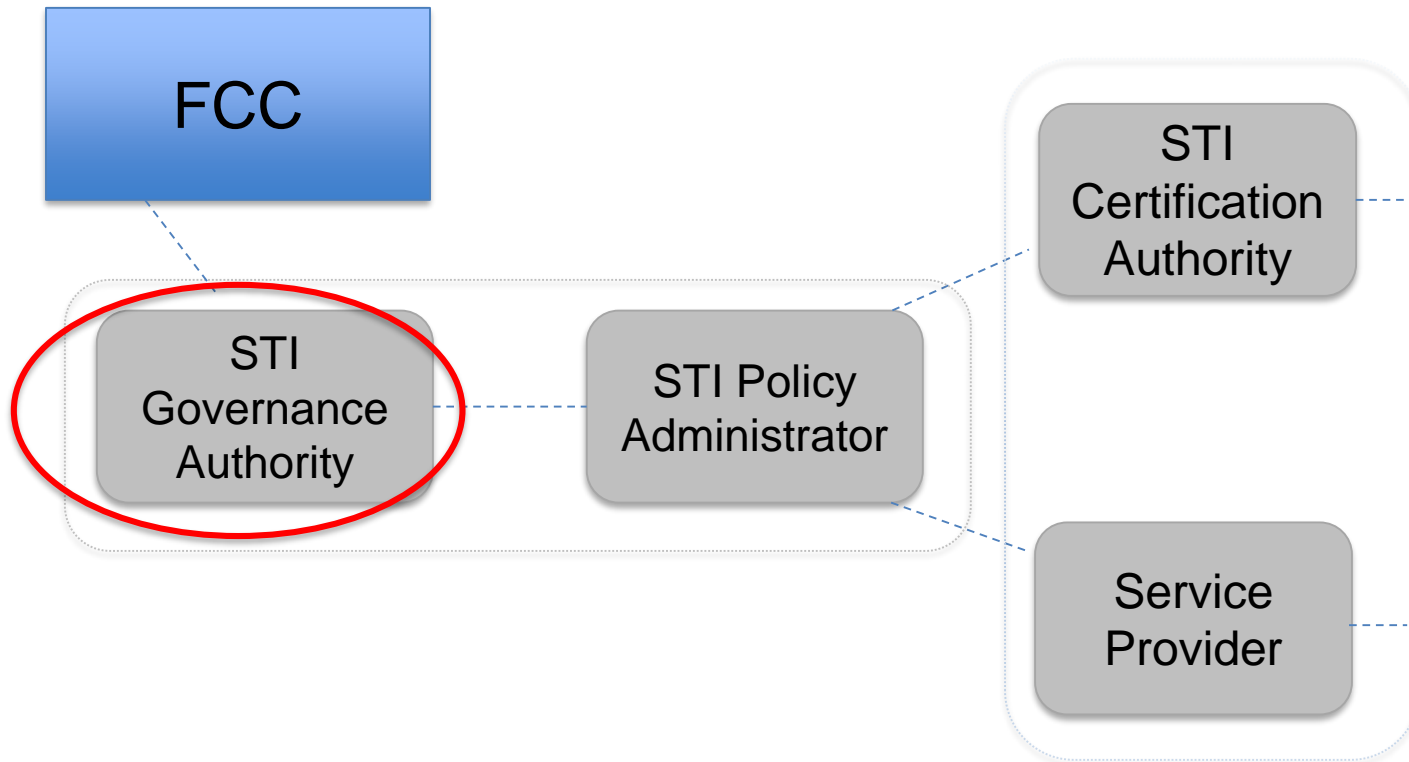

Key roles:

STI Governance Authority (STI-GA)

- Defines the rules governing STI Certificates
- Selects the STI Policy Administrator

Industry-Developed SHAKEN Governance Model

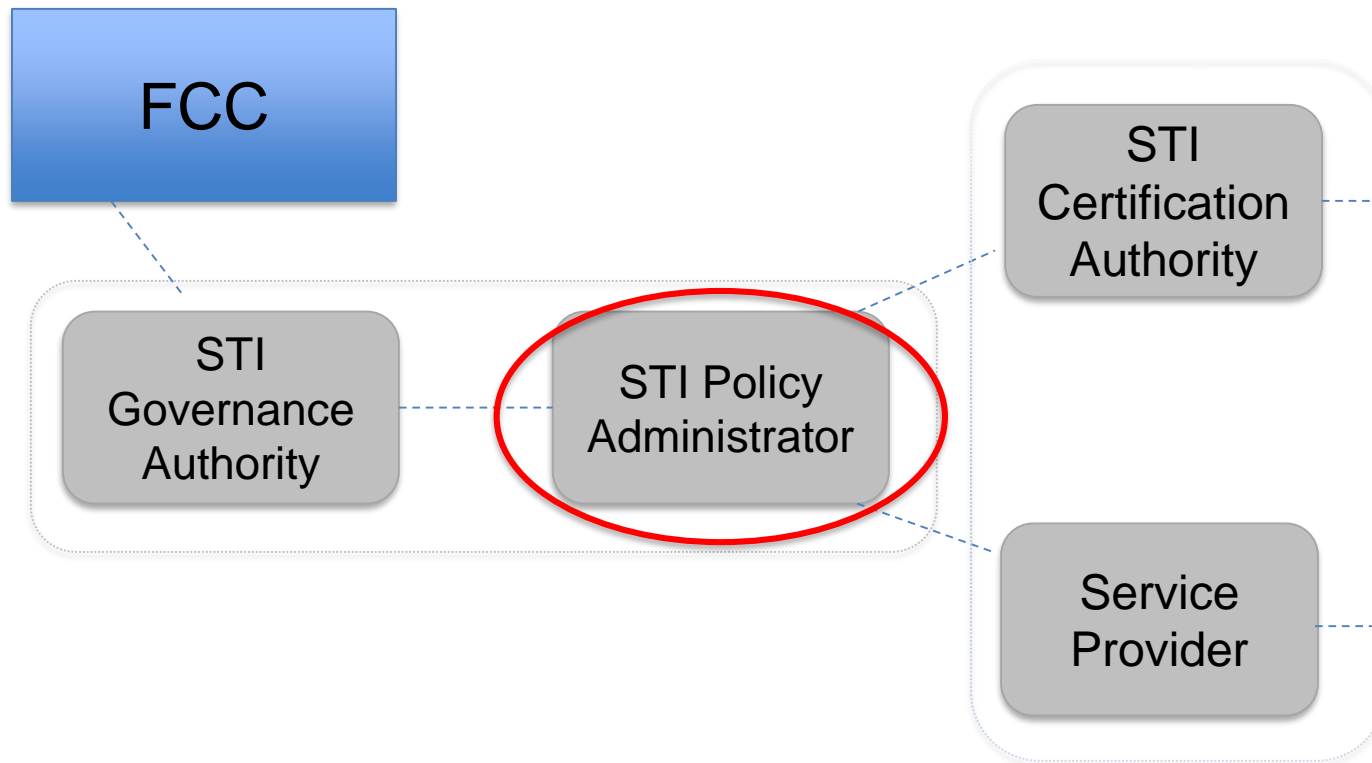

Key roles:

STI Policy Administrator (STI-PA)

- Applies the rules set by the STI-GA
- Approves STI-CAs
- Validates that service providers are authorized to obtain STI Certificates
- Issues “Service Provider Code” (SPC) tokens
- Maintains a secure list of all authorized STI-CAs and Certificate Revocation List (CRL)

Cross-Border SHAKEN

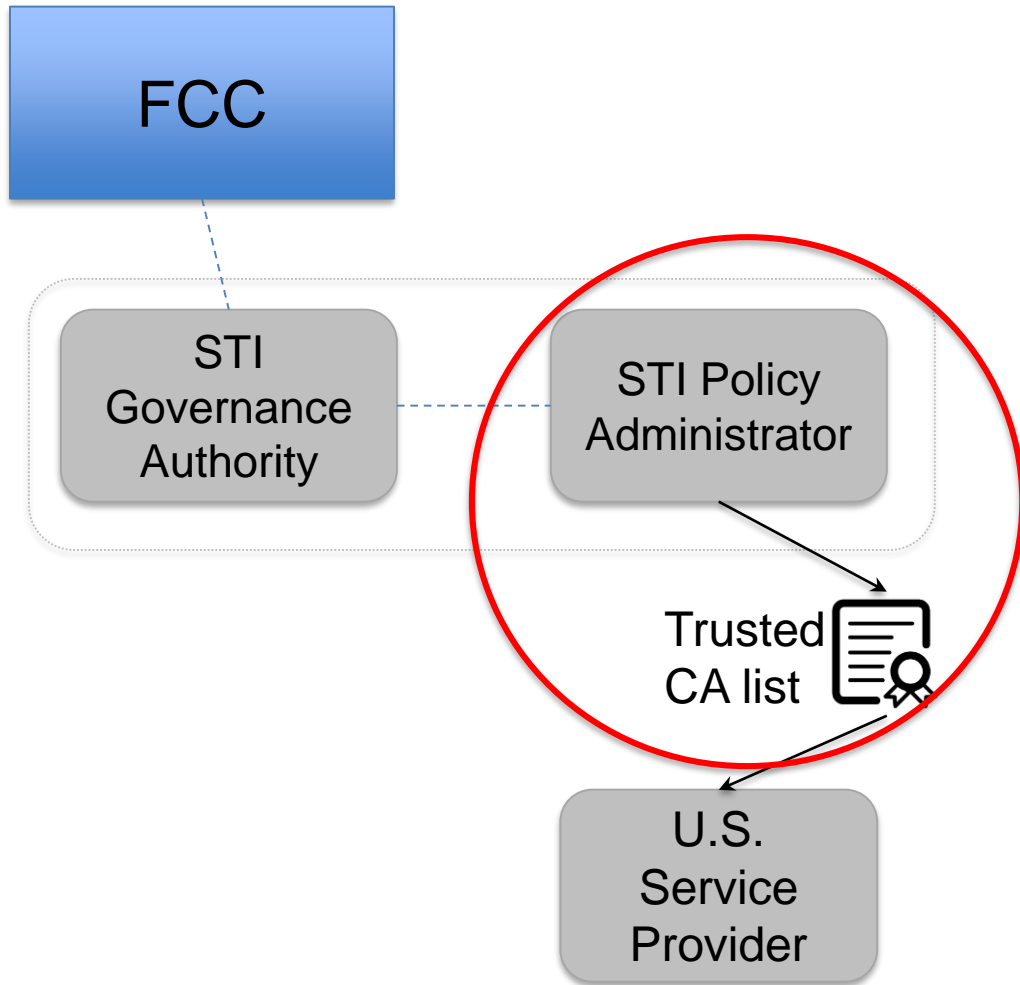

Cross-Border SHAKEN

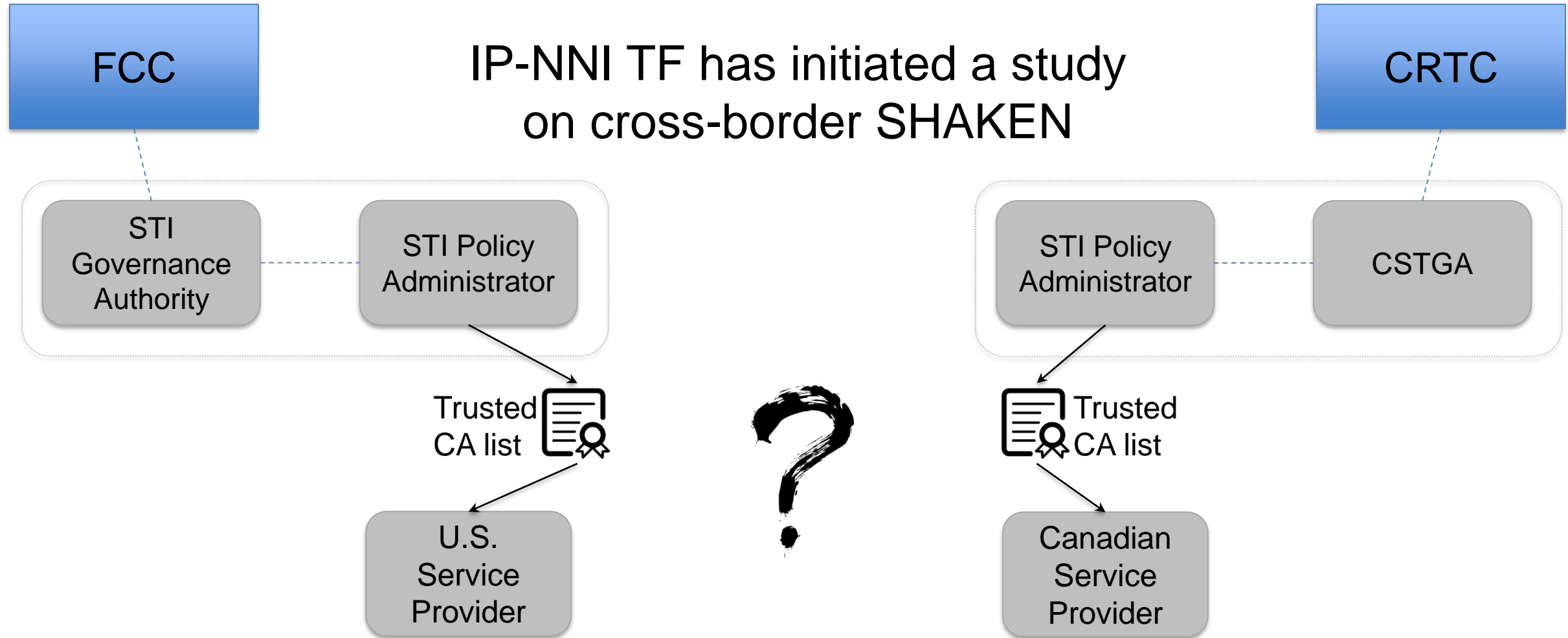

Outline

- SHAKEN Governance Model
- **Call Authentication Trust Anchor Working Group**
- Secure Telephone Identity- Governance Authority (STI-GA) Update
- Canadian Governance Authority

GA Selection Process



Federal Communications Commission
Washington, D.C. 20554

December 7, 2017

The Honorable Travis Kavulla
Commissioner,
Montana Public Service Commission
Chair, North American Numbering Council (NANC)
1701 Prospect Avenue
P.O. Box 202601
Helena, MT 59620-2601

Re: Call Authentication Trust Anchor: Selection of Governance Authority and Timely
Deployment

Dear Chairman Kavulla:

As you are aware, the Commission has issued a Notice of Inquiry (NOI) on deploying a call authentication system based on the SHAKEN and STIR standards.¹ Such a system would ensure that many telephone calls can be properly attributed to their callers, increasing the security of the network and reducing the threat of illegal and fraudulent spoofed calls. The continuing need to protect consumers from fraudulent and illegal spoofed calls requires that we deploy a call authentication system as soon as practicable. We seek the recommendations of the NANC on timing and governance of a call authentication system and ask that you refer this matter to the Call Authentication Trust Anchor Issues Working Group for its consideration.

The SHAKEN/STIR standards require a call authentication system to be performed by a Policy Administrator (PA), whose operational rules and standards will be set by a Governance Authority (GA). The standards specify a single GA to set universal, non-discriminatory, and transparent standards for the PA, participating service providers, and other entities using the system.

NANC Recommendations

Report on Selection of Governance Authority and Timely Deployment of SHAKEN/STIR

1 Introduction

Consistently, Caller ID spoofing and robocalling generate the largest number of consumer complaints to the Federal Communication Commission (FCC), with an estimated 2.4 billion robocalls received by Americans per month in 2016 alone. Recognizing this fact, on July 14, 2017, the FCC issued a Notice of Inquiry seeking comment on the FCC's role in promoting SHAKEN/STIR—an industry-developed set of protocols and operational procedures designed to authenticate telephone calls and mitigate spoofing and illegal robocalling.¹ As part of this administrative process, the FCC has directed the Call Authentication Trust Anchor Working Group (CATA WG) of the North American Numbering Council (NANC) to investigate a variety of issues associated with the SHAKEN/STIR system.² Specifically, the FCC directed the NANC CATA WG to address the following substantive issues:

Timeline/Milestones

May 4, 2018
Submission of
NANC report
to FCC

November 4, 2018
Issuance of PA RFP

May 2019
Selection of
PA

August 4, 2018
Establishment
of GA

February 4, 2019
Deadline for RFP
responses

You are
here

Service provider deployment for end-to-end SIP calls can take place concurrently

Outline

- SHAKEN Governance Model
- Call Authentication Trust Anchor Working Group
- **STI-Secure Telephone Identity- Governance Authority (STI-GA) Update**
- Canadian Governance Authority

Status of Implementation

- A STI-GA and STI-PA are needed to provide a standard framework for the verification of calling numbers and the exchange of call “signatures”.
 - ATIS was selected as the STI-GA and an STI-GA board representing a broad range of service providers convened in August 2018.
 - The RFP process for selection of the STI-PA will be completed in May 2019.
- Several service providers have committed to begin implementation prior to the establishment of the STI-GA and STI-PA.
 - Network testing began in December 2018.
 - Several service providers have stated that they expect to sign/verify calls within their networks and exchange certificates with those providers who are ready before the end of 2019. Some have already started.

Other STI-GA Work

- The STI-GA Board has established one committee and three task forces.
 - The Technical Committee (TC) provided significant input into the Technical Requirements Document and other aspects of the RFP. The TC advises the Board on other technical issues.
 - The RFP Task Force, working with the TC, developed the RFP, evaluated responses and provided input to the STI-GA Board related to the selection of the STI-PA.
 - The Corporate Structure Task Force continues to evaluate the practicality of a separate corporate structure with a goal of having one in place upon the expiration of ATIS' two-year term in June 2020, if desired by the Board.
 - The Cost Recovery Task Force is examining long-term STI-GA and STI-PA funding models as well as the potential recoupment of STI-GA Board member start-up contributions.

Benefits and Limitations of SHAKEN/STIR

Benefits

1. Consumers will have more information when deciding whether to answer a call.
2. The identity of the originating carrier is included with the call authentication information. Knowing the originating carrier will accelerate illegal robocall tracebacks and enforcement.

Limitations

1. It can only identify if a call was not spoofed – not whether or not the caller is a scammer.
2. It only works on an IP end-to-end call path.
3. The benefits will not fully materialize until all service providers implement the SHAKEN/STIR standards.

Future of the STI-GA

- Negotiate contract with the chosen STI-PA vendor.
- Oversee the building, testing, and implementation of the STI-PA and the initial framework of the STIR/SHAKEN ecosystem.
- Monitor the early activity of the STIR/SHAKEN ecosystem to ensure stability and recommend changes/updates.
- Manage the STI-PA, STI-CAs, and the overall architecture to respond to evolving threats and ensure long-term viability of STIR/SHAKEN.
- Identify open issues and bring those issues to the appropriate industry forum for resolution.

Outline

- SHAKEN Governance Model
- Call Authentication Trust Anchor Working Group
- Secure Telephone Identity- Governance Authority (STI-GA) Update
- **Canadian Governance Authority**

Canadian Deployment of STIR/SHAKEN

- January 2018 the CRTC Compliance and Enforcement Sector issued CRTC 2018-32, *“Measures to reduce caller identification spoofing and to determine the origins of nuisance calls”*.
- That decision directed the Canadian telecom industry to:
 - Develop a traceback process at the CISC Network and Technical Working Group (NTWG),
 - Report on the status of the industry readiness for “authentication and verification of caller ID information for IP voice calls” using STIR/SHAKEN, through NTWG
 - Establish a governance framework. (CRTC did not provide any specific direction in this regard.)

Canadian Secure Token Governance Authority (CSTGA)

- A small group of carriers have incorporated the CSTGA to fulfill the role of GA, based on the governance model in ATIS-1000080.
 - The detailed corporate structure continues to be a work in progress.
- A technical advisory committee (TC) was established and has produced a Canadian technical requirements document (CTRD) for SHAKEN governance.
 - TC is evaluating technical and operational issues relating to the PA and CA roles, including exchange of international certificates, beginning with Canada/U.S.
- Informal discussions are ongoing with a number of vendors who are interested in fulfilling the role of PA for Canada.
- There is ongoing dialogue with CRTC staff regarding formal endorsement of the CSTGA as the Canadian GA.

Questions

Thank you for attending
*The SHAKEN Governance Model: Setting Robocall Mitigation
Protocols into Action in the Network Webinar*

All registered attendees will receive a follow up
email containing links to a recording and the slides
from this presentation.

For information on the SHAKEN Governance Authority, visit
<http://www.atis.org/sti-ga/>